

Definition: all metals reusable slotted self-locking nut, with nylon insert

Threading: standard to ISO 965-2

Characteristic and performance test: for steel ISO 898-2 / ISO 2320
for stainless steel ISO 3506-2 / NFE 25035



d	pitch	s	h	m	d ₂ *	s ₁
M 4	0,70	7,00	7,70	3,30	12,00	1,10
M 5	0,80	8,00	8,70	4,50	14,00	1,30
M 6	1,00	10,00	10,10	5,60	18,00	1,40
M 8	1,25	13,00	12,00	7,30	22,00	1,60
M 10	1,50	16,00	14,80	8,40	27,00	1,80
M 12	1,75	18,00	18,40	11,40	27,00 / 30,00 **	1,80
M 14	2,00	21,00	20,50	13,30	32,00	2,40
M 16	2,00	24,00	23,70	14,20	40,00	3,20

Sizes: * Only given as an indication. On request for other type and other diameter of washers

** Stainless steel for diameter 27; steel for diameter 30.

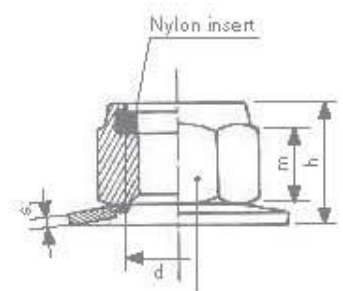

Marking of the class of the material and manufacturer's initials standard to the ISO 898-2

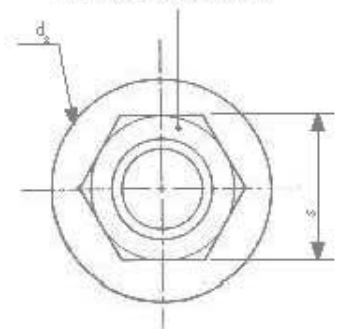

Quality class	Classification	Range of application
Class 8 steel / Grade 5	QV	Self color -40° C + 120° C ⁽¹⁾
Class 10 steel / Grade 8	QK	
Stainless steel A2-70	ZE	
Stainless steel A4-80	ZH	

⁽¹⁾ Values are only given as an indication

Surface treatment (standard to ROHS requirements)

Electrolytic coating (steel)	Yellow	ZJ	ISO 4042
	White Lanthane Ⓞ Finish	ZL	400 h
	White Lanthane Ⓞ Finish + Top coat	ZF	600 h
Zinc lamellar (steel)	600 h to 1000 h salt spray		on request
Antigalling (stainless steel)	Stanal Ⓞ 400	ST	
	Sherardisation (NF EN 13811)	SH	
Self Color		BT	

Example of ordering code

	Type	Diam X pitch	Class	Protection	
classification	EUM	100150	ZH	ST	00
working	EUM	M10 X 1,50	A4 80	Stanal Ⓞ	*

*Standard size