



## ERM

### HFR FLANGE NUT

### WITH FREE WASHER ALL METALS – METRIC

**Definition:** all metals reusable slotted self-locking hexagon flange nut with free washer

**Threading:** standard to ISO 965-2

**Characteristic and performance test:** for steel ISO 898-2 / ISO 2320  
for stainless steel ISO 3506-2 / NFE 25035



d	pitch	s	h	m	d <sub>2</sub> <sup>*</sup>	s <sub>1</sub>
M 4	0,70	7,00	7,00	2,60	12,00	1,10
M 5	0,80	8,00	8,50	3,00	14,00	1,30
M 6	1,00	10,00	9,00	4,50	18,00	1,40
M 8	1,25	13,00	11,00	4,80	22,00	1,60
M 10	1,50	16,00	13,40	6,00	22,00 / 27,00	1,80
M 12	1,75	18,00	15,80	7,20	27,00	1,80
M 14	2,00	21,00	17,80	8,40	30,00	2,40
M 16	2,00	24,00	19,80	9,50	40,00	3,20

Sizes: \* Only given as an indication. On request for other type and other diameter of washers

Quality class	Classification	Range of application
Class 8 steel / Grade 5	QV	Self color -50° C +300° C <sup>(1)</sup>
Class 10 steel / Grade 8	QK	
Stainless steel A2-70	ZE	Composite atmosphere -200° C +400° C <sup>(1)</sup>
Stainless steel A4-80	ZH	

Others: Brass - Bronze - Light alloy - Titanium ...

<sup>(1)</sup> Values are only given as indication

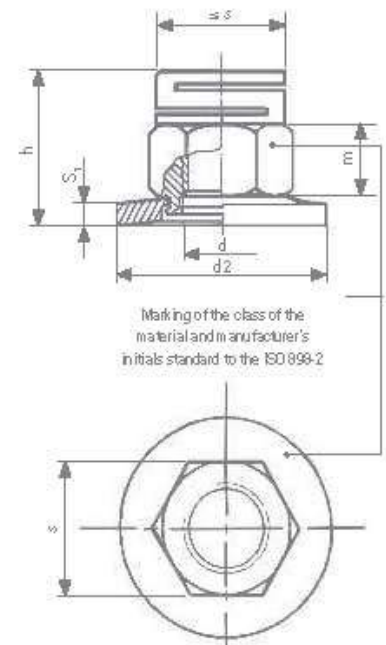

Surface treatment (standard to ROHS requirements)			
Electrolytic coating (steel)	Yellow	ZJ	ISO 4042
	White Lanthane ® Finish	ZL	400 h
	White Lanthane ® Finish + Top coat	ZF	600 h
Zinc lamellar (steel)	600 h to 1000 h salt spray		on request
Antigalling (stainless steel)	Stanal ® 400	ST	
	Sherardisation (NF EN 13811)	SH	
Self Color		BT	

Example of ordering code					
	Type	Diam X pitch	Class	Protection	
classification	ERM	100150	ZH	ST	01
wording	ERM	M10 X 1,50	A4-80	Stanal ®	*

\*Standard size

**On request:** other materials, plating, sizes, imperial thread